



## Installation, operation and maintenance instructions



These instructions are  
to be passed on by the  
fitter to the user

Please observe the additional installation  
instructions for panic and emergency exit  
door locks MBW10.

**FUHR**

# Contents

1	Introduction.....	3
2	Important information/safety instructions.....	4
3	Delivery scope.....	5
4	Installation instructions.....	7
4.1	Routing and drilling operations.....	7
4.1.1	Cable-laying depending on the door design.....	8
4.1.2	Routing for the electronic drive unit in the door leaf.....	8
4.1.3	Routing for the tappet contacts in the door leaf.....	9
4.1.4	Routing for the control unit casing in the door frame.....	9
4.1.5	Routing for the switching power supply unit in the door frame.....	10
4.1.6	Drilling for the surface-contact device's cable.....	10
4.1.7	Drilling for the 230 V power supply cable.....	11
4.1.8	Safety instructions.....	11
4.1.9	Screws for fixing individual components.....	11
4.2	Installation.....	12
4.2.1	Installation of the tappet contacts in the door leaf.....	13
4.2.2	Installation of the multipoint locking system in the door leaf.....	14
4.2.3	Installation of the cable guides, end caps and cover plates in the door leaf.....	15
4.2.4	Installation of the magnetic contact in the door frame.....	16
4.2.5	Installation of the surface-contact device in the door frame.....	16
4.2.6	Installation of the control unit casing in the door frame.....	17
4.2.7	Installation of the switching power supply unit (transformer) in the door frame.....	18
5	Commissioning.....	19
5.1	Fabricator's function check.....	19
5.2	Commissioning on site.....	19
5.3	The radio keys (radio-controlled remote control).....	20
5.4	Master radio key.....	20
5.5	Tuning in and deleting radio keys.....	21
5.5.1	Tuning in individual radio keys (max. 25).....	21
5.5.2	Deleting individual radio keys (except the master key).....	22
5.5.3	Deleting all radio keys (except the master key).....	23
6	External connection options.....	24
6.1	Control unit casing circuit board.....	24
6.1.1	Application examples for circuit board assignment.....	26
6.2	The drive unit's multi-functional jack.....	27
7	Maintenance and care.....	28
7.1	Contact device.....	29
8	Troubleshooting.....	30
8.1	Adjustment of strike plates/one-piece strike plates and latch changing.....	31
9	Technical data.....	32
9.1	FUHR <b>multitronic</b> set.....	32
9.2	FUHR <b>multitronic</b> radio key (remote control).....	32
9.3	FUHR <b>multitronic</b> control unit with radio receiver.....	32
9.4	FUHR <b>multitronic</b> drive unit.....	32
9.5	FUHR <b>multitronic</b> switching power supply unit.....	33
10	Optional accessories.....	34
11	Wiring diagram.....	36



For this manual in other languages see [www.fuhr.de](http://www.fuhr.de)

# 1 Introduction

The FUHR multipoint locking system **multitronic 881** locks doors electromotively – at all times and fully automated.

- Particularly reliable – strong and fast – due to two parallel high performance drives.
- This conserves energy as the door always closes imperviously.
- Enables secure locking of main entrance doors, apartment doors or back doors.
- Suitable for use with all door materials.
- All locking components can be operated either electromotively via a radio key, mechanically via the profile cylinder's key, or from the inside via the door lever handle.
- The electricity and data transfer is carried out from the door frame to the door leaf via a wireless transmission device. Spring-loaded contact pins enable the door leaf to be unhinged for e.g. for decorating purposes at any time.

## The standard locking and unlocking functions in detail:

**Special functions are described in chapter 6.**

### Locking (closing):

All locking components are locked automatically 3 sec. after the door has been closed over. (This can however in emergency situations - e.g. in the event of power failure - also be carried out mechanically by turning the key 4 times.)

### Unlocking (opening) from the outside:

- By means of the radio key provided
- Alternatively by using the free-running profile cylinder's key (depending on the drive-gear position; 4 turns!)
- Optionally by means of another access system e.g. transponder, code lock, finger print recognition, eye scanner or similar (release signal via potential-free contact!)

### Unlocking (opening) from the inside:

- Via the door lever handle as usual
- Alternatively by using the free-running profile cylinder's key (depending on the drive-gear position; 4 turns!)
- Alternatively by means of the radio key provided
- Optionally via a domestic intercom system (6-12 V AC!)
- Optionally via a wireless wall-mounted push-button switch
- Optionally by means of another access system e.g. transponder, code lock, finger print recognition, eye scanner or similar (release signal via potential-free contact!)
- As well as access control systems pertaining to contemporary BMS devices (Building Management Systems) (24 V DC processor impulse!)

The locked mode is indicated by two brief acoustic signals. Simultaneously a red LED located on the control unit on the internal side of the door indicates the locked mode. A green LED indicates the unlocked mode.

**Do not operate the lever-handle during the electrical locking and unlocking procedure!**

### Further electrical connections are available for:

- Alarm systems
- Access control systems (fingerprint scanner, code lock, transponder etc.)
- Illuminated fixed pad handles/glazed units
- Electrically operated door openers (e.g. for disabled accessible doors = 'barrier-free building')

### Note!

All images, dimensions, product and design related information contained in these instructions represent the latest developments regarding the FUHR multipoint locking system **multitronic 881** at the time of printing. This product is subject to a CIP (continuous improvement process) and is constantly enhanced to reflect the latest technology. For the purpose of your satisfaction, we reserve the right to implement changes to this product. Model and product claims cannot be lodged. The latest version of these instructions is published on our website [www.fuhr.de](http://www.fuhr.de).

- 1 INTRODUCTION
- 2 IMPORTANT INFORMATION
- 3 DELIVERY SCOPE
- 4 INSTALLATION INSTRUCTIONS
- 5 COMMISSIONING
- 6 EXTERNAL CONNECTION OPTIONS
- 7 MAINTENANCE AND CARE
- 8 TROUBLE-SHOOTING
- 9 TECHNICAL DATA
- 10 OPTIONAL ACCESSORIES

## 2 Important information/safety instructions

These instructions are aimed at door fabricators and contain important information regarding installation, commissioning and operation pertaining to the FUHR multipoint locking system **multitronic** 881. Please read carefully **prior** to installation and commissioning. The points raised here provide supplementary information to the FUHR product information M3/3. The importance of their compliance must be pointed out to builders and end-users. In the event of non-compliance with these imperative instructions, faultless system operation cannot be warranted.

We assume that the installation as well as commissioning is carried out exclusively by professional staff.

Text passage denoting this symbol  is relevant to safety and must be strictly adhered to.

The FUHR multipoint locking system **multitronic** 881 has been designed and manufactured taking safety-related regulations and harmonised standards into account. This product's safety features are an essential pre-requisite for the EN 14846 accreditation. Therefore no alterations or modifications may be carried out other than those described in these instructions.



**The safety of the FUHR multitronic product largely depends on its correct installation and regular maintenance! The installation of the electronic components requires particular care, since abrasion points, defective cables, damaged contacts, etc. affect security and can lead to the malfunction of the system. Please ensure that all components are in perfect functioning condition prior to installation. Damaged or defective components may not be used under any circumstances. Use the locking system only in technically perfect condition! Malfunctions that impair security are to be eliminated immediately. Until the malfunction has been eliminated, the drive unit is to be switched off and operated mechanically! The power supply unit's power feed is to be disconnected when working on the locking system and live components.**

The FUHR multipoint locking system **multitronic** 881 has been engineered to be used in conjunction with the provided FUHR **multitronic** components. All specified components must be installed to ensure the requirements outlined in EN 14846 are met. We accept no liability for improperly installed systems and/or the use of non-original or non factory approved system accessory parts. The modification of components or the use of non approved accessory components can cause malfunctions. Material damage or personal injury resulting from non-compliance with the installation, operation and maintenance instructions or inappropriate operation invalidates the warranty. We assume no liability for any consequential damage.



**The FUHR multipoint locking system multitronic 881 must be protected from humidity. It is not suitable for areas with high humidity and chemical substances.**

The FUHR multipoint locking system **multitronic** 881 has been primarily designed for installation in main entrance doors, apartment doors and back doors. Products manufactured in accordance with EN 14846 requirements provide a high level of personal protection and adequate protection against intrusion when fitted to a suitable door and door frame. The system with 2 hook bolts (type 3) has been tested and certified in accordance with DIN EN 179. The variants with 2 round bolts (type 8) and with 2 hook and dual round bolts (type 11) have been tested and certified in accordance with DIN EN 1125. For this purpose durability testing in the highest grade (grade 7) with 200,000 operations was carried out successfully. The product was tested, approved and certified for fire resistance on a single leaf aluminium door by MPA Braunschweig (certification number PB 3019/2006).



**For use in heavily frequented doors (more than 50 operations per day) e.g. in public or office building projects, it is necessary to use either of the two day-latch functions during busy periods (refer chapter 6.1).**

The installation steps depicted on the following pages serve as a schematic diagram. Due to the numerous profiles available on the market, there may be slight deviations in specific points. It is therefore imperative that the profile-related routing drawing provided with the FUHR **multitronic** set is adhered to. Please contact your sales partner or the manufacturer in the event of discrepancies or queries.

The indicated sequence in these installation instructions is exemplary. The sequence may be varied if required.

### IMPORTANT!

**All components contained in the set (particularly the control unit and the radio key) are coordinated and should not be used in conjunction with other sets.**

### 3 Delivery scope

**One-piece keep or individual keeps**

Profile related version,  
incl. magnetic contact



**Multipoint locking system multitronic 881**

incl. electromotive drive unit

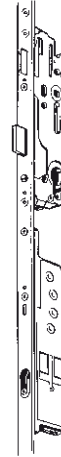

**Control unit with radio receiver and visual locking indicator**

Preassembled cable connectors (length 200 and 300 mm)



**Switching power supply unit (transformer)**

Profile related version,  
230 V AC input/12 V DC output, Cable connectors 230 V  
(length 3000 mm - surface- mounted cable), earth/ground  
cable (length 400 mm) and 12 V (length 200 mm)  
preassembled



**Surface-contact device for electricity and data transfer**

Preassembled cable connector (length 250 mm)



**Tappet contacts for electricity and data transfer**

Cable connector (length 4000 mm), with preassembled  
multi-functional jack



1 INTRODUCTION

2 IMPORTANT INFORMATION

3 DELIVERY SCOPE

4 INSTALLATION INSTRUCTIONS

5 COMMISSIONING

6 EXTERNAL CONNECTION OPTIONS

7 MAINTENANCE AND CARE

8 TROUBLE-SHOOTING

9 TECHNICAL DATA

10 OPTIONAL ACCESSORIES

**Radio key**

to be handed over to the end user;  
3-channel radio key as remote control,  
1 pc. with red buttons = master key  
2 pcs. with turquoise buttons

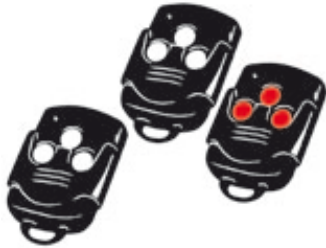

**Cover plate, cable guides and end caps**

for safe cable-laying (only for doors with Euro groove);  
2 m. cover plate  
6 pcs. double cable guides  
2 pcs. end caps

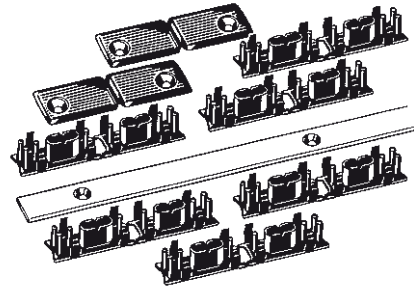

**Cable protection sleeves**

3 pcs.



**Profile-related routing drawing**

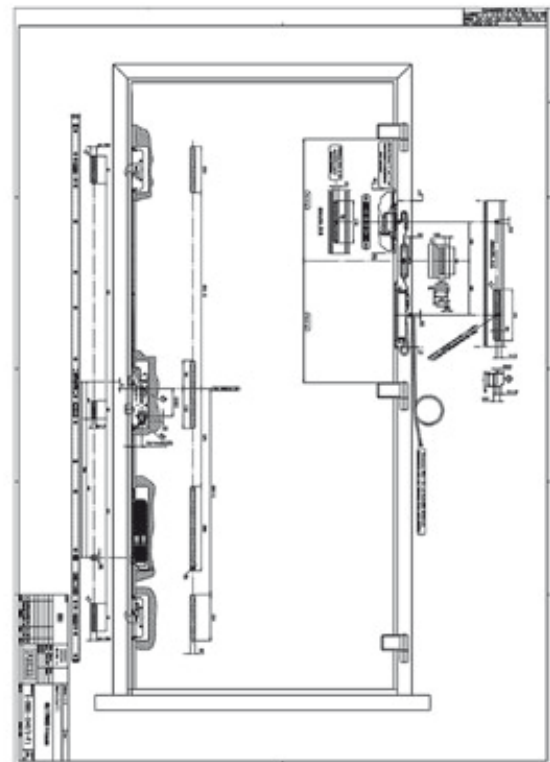

## 4 Installation instructions

### 4.1 Routing and drilling operations

The routings for the FUHR multipoint locking system **multitronic** 881 are carried out in accordance with the routing drawing provided.

In addition to the conventional routings for FUHR multipoint locking systems, for example on **multisafe** 855, only 2 additional routings in the door leaf and the door frame are required. These installation instructions therefore only describe the additional routing and drilling operations for the electronic locking mechanism.

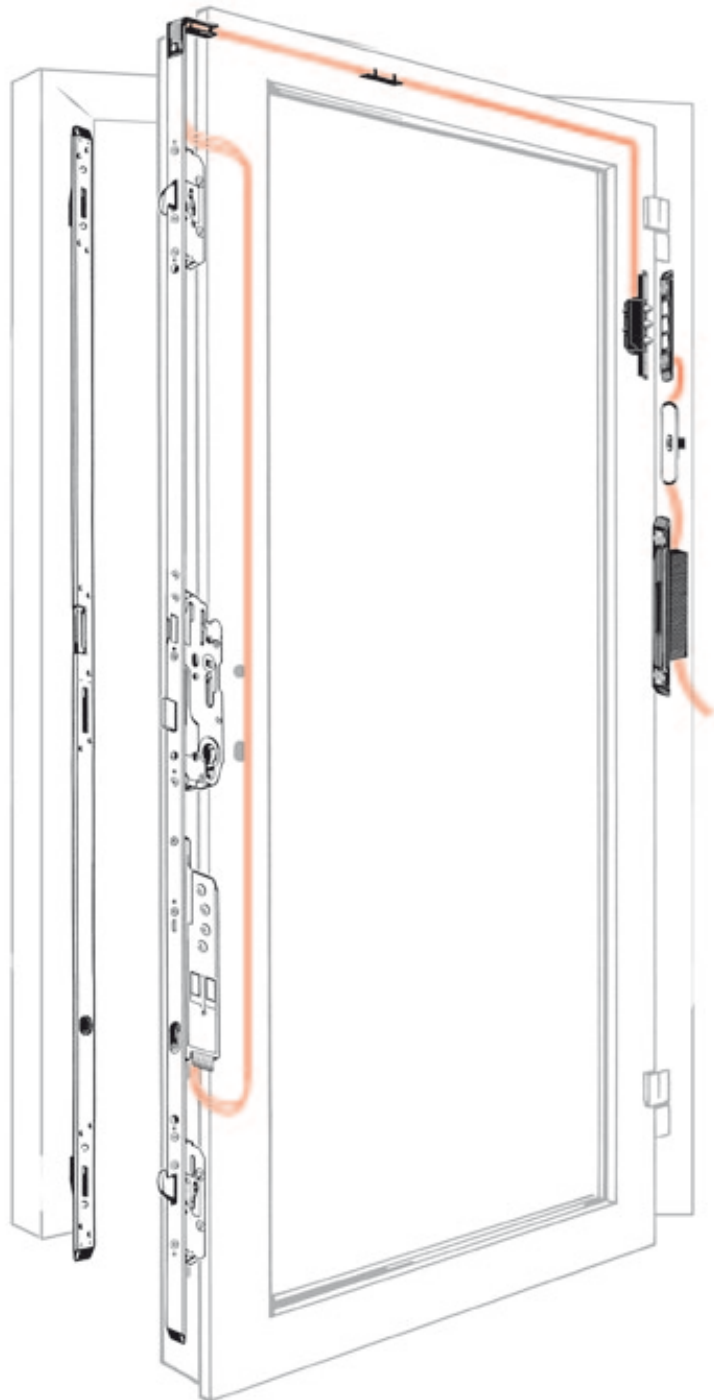

## 4.1.1 Cable-laying depending on the door design

**Version A** – e.g. for PVC doors:

Cable-laying in the Euro groove.



**Deburr the cable feedthrough hole and insert the cable protection sleeves provided.**

**Version B** – e.g. for aluminium doors:

If the cable is to be laid in the glazing rebate's Euro groove, a  $\varnothing$  10 mm drill hole is to be drilled in the glazing rebate area.



**Deburr the cable feedthrough hole and insert the cable protection sleeve provided.**

The 230 V electricity cable is a surface-mounted cable. Conduit must be used for concealed cabling. The door frame must be earthed/grounded.

The cable-laying for version A is described in the following installation steps.

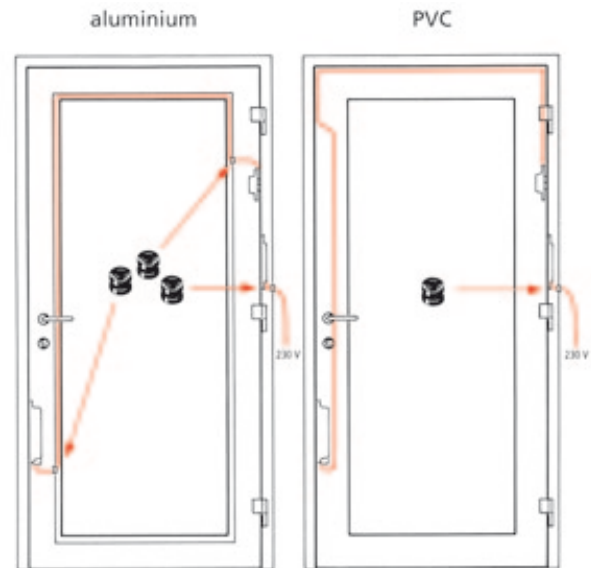

## 4.1.2 Routing for the electronic drive unit in the door leaf

Routing in compliance with the separate routing drawing between the main lock and the bottom additional locking point

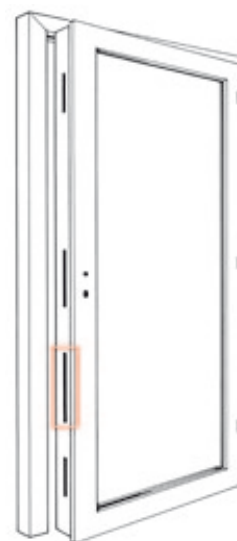



### 4.1.3 Routing for the tappet contacts in the door leaf

Routing in compliance with the separate routing drawing on the hinge side of the door leaf



**Make sure that the surface-contact device and the tappet contact device are aligned accurately horizontally. Refer to chapter 4.1.6.**



### 4.1.4 Routing for the control unit casing in the door frame

Routing in compliance with the separate routing drawing on the hinge side of the door frame face (**on the inside of the building**)



#### 4.1.5 Routing for the switching power supply unit in the door frame

Routing in compliance with the separate routing drawing on the hinge side of the frame profile



#### 4.1.6 Drilling for the surface-contact device's cable

Drilling in compliance with the separate routing drawing in the frame profile, laterally at the same height as the tappet contact device



**Make sure that the surface-contact device and the tappet contact device are aligned accurately horizontally. Refer to chapter 4.1.3.**



## 4.1.7 Drilling for the 230 V power supply cable

Drilling in compliance with the separate routing drawing on the reverse side of the profile within the routing to accommodate the switching power supply unit



**This drill hole must be deburred carefully at both ends! Insert the cable protection sleeve provided in the drill hole to protect the 230 V cable. The cable must be protected against abrasion and securely fixed in order to prevent tractive forces.**



## 4.1.8 Safety instructions



**All routing and drilling work must be deburred carefully. The cables must be securely fixed in this area in order to prevent abrasion. All routing and drilling swarf must be carefully removed from the profiles.**

## 4.1.9 Screws for fixing individual components

Conventional fenestration screws with a maximum screw head diameter of 7 mm and a maximum screw diameter of 4.5 mm may be used. The PVC components (switching power supply unit, surface-contact device etc.) are to be fixed with screws with a **maximum length of 20 mm**. To fix the metal components (faceplates, keeps etc.) select a screw length according to the requirements. Depending on the profile material, screw holes may have to be pre-drilled with an appropriate drill.

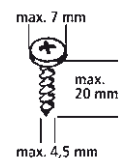

**It is imperative that all screws are hand-tightened, as some components are made of PVC and may be damaged by the excessive force that a cordless screwdriver can exert.**

**It is essential that the surface-contact device and the tappet contact device are aligned accurately.**

## 4.2 Installation



The installation requires exceptional care. This applies particularly to the electronic components, as routing and drilling swarf, abrasion points and defective cables can lead to the device malfunctioning.

Avoid positioning fixing materials (e.g. frame-fixing screws) in areas where electronic components are located!

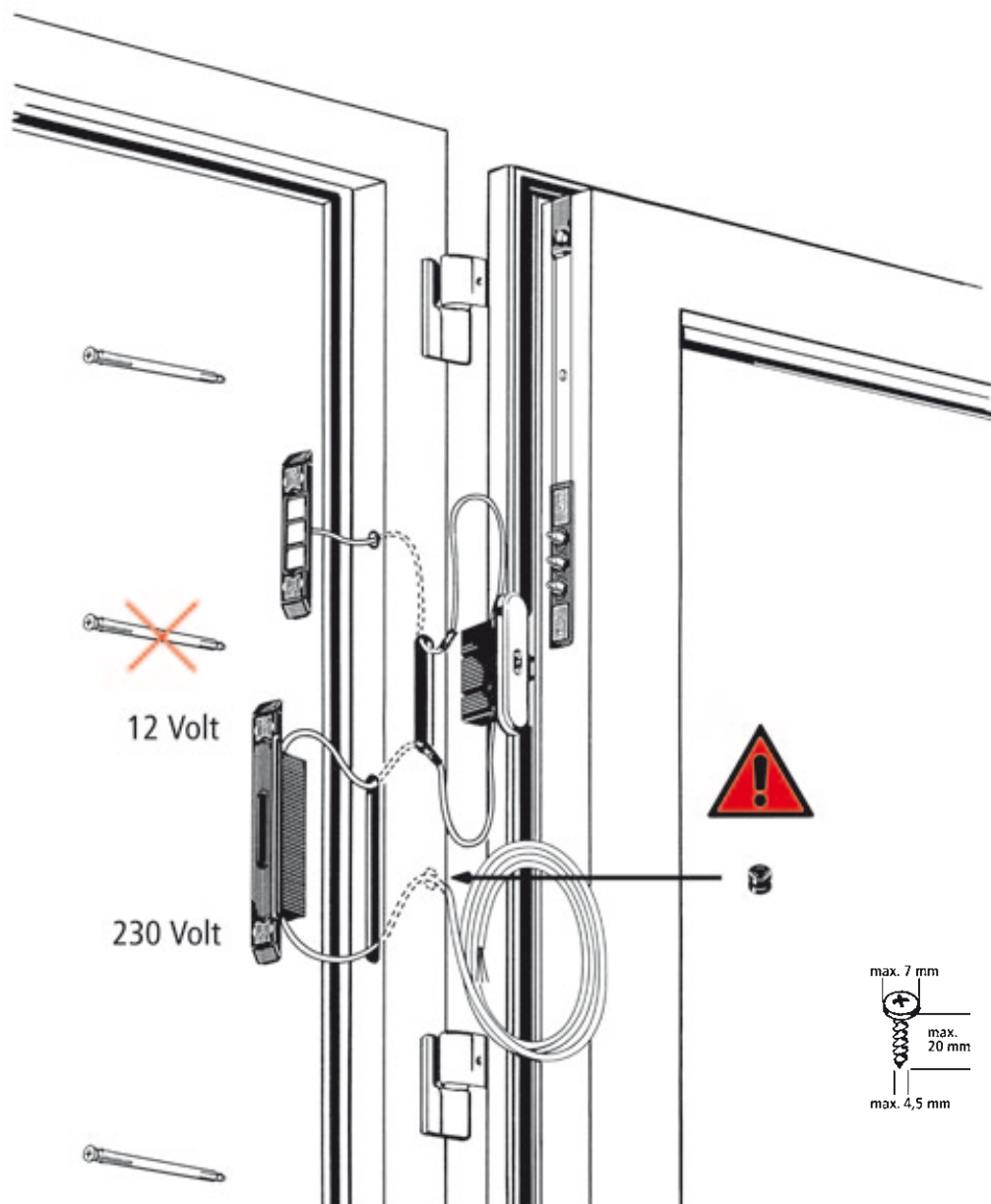

## 4.2.1 Installation of the tappet contacts in the door leaf

The electricity and data transfer control unit for FUHR **multitronic** may be used on left or right handed doors.

**On DIN left-handed doors** the tappet contact is installed as provided.

**On DIN right-handed doors** the cable is placed in the guide channel on the rear side of the casing.



**Check the polarity (plus/minus) before installing the tappet contacts, refer to the components' identification marking:**  
**DIN right-handed** = Plus symbol on the bottom  
**DIN left-handed** = Plus symbol on the top

1. Remove the silver covers from the tappet contact device.
2. Insert the tappet contact device into the door leaf's routed recess.
3. Lay the cable with the green plug in the channel above the door.
4. Screw-fix the casing to the door leaf profile.
5. Replace the covers.
6. Insert the green plug in the additional locking point's top routing and lead it down to the routed recess for the electrical drive unit.



**Note: DIN right-handed = doors with the hinges located on the right hand side of the door (viewed from the inside).**

DIN right-handed



DIN left-handed



DIN right-handed



DIN left-handed

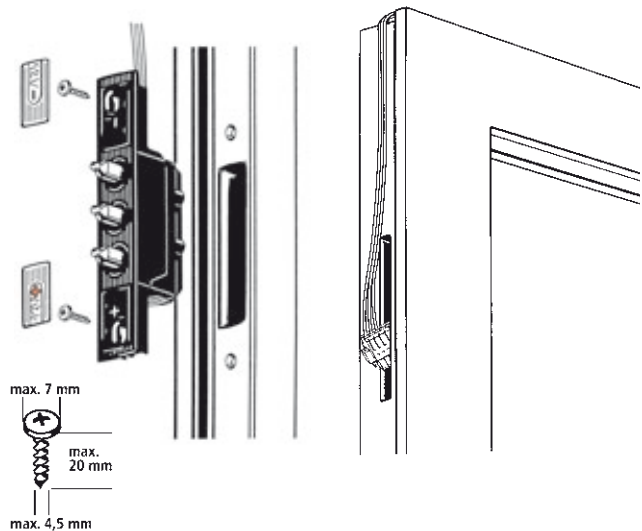

## 4.2.2 Installation of the multipoint locking system in the door leaf

1. Connect the tappet contact device's green plug to the corresponding contact plug on the electrical drive unit.
2. Screw-fix the plugs with a small screwdriver.



**PLEASE NOTE!** It is imperative to carry out this screw-fixing. The screw joint warrants permanent contact for the electricity and data transfer, and safeguards against vibration and shock.

3. Insert the cable and FUHR multipoint locking system **multitronic** into the routed recess.



**In doing so, ensure that the cables are neither kinked, trapped nor damaged.**

4. Screw-fix the multipoint locking system's faceplate. Fix the screws in a straight manner in order to prevent the connecting-rods being jammed by the screws.



**PLEASE NOTE!** The connecting-rodshave to be able to move unhindered. Friction caused by screws or too narrow profile guide grooves cause operational malfunction.

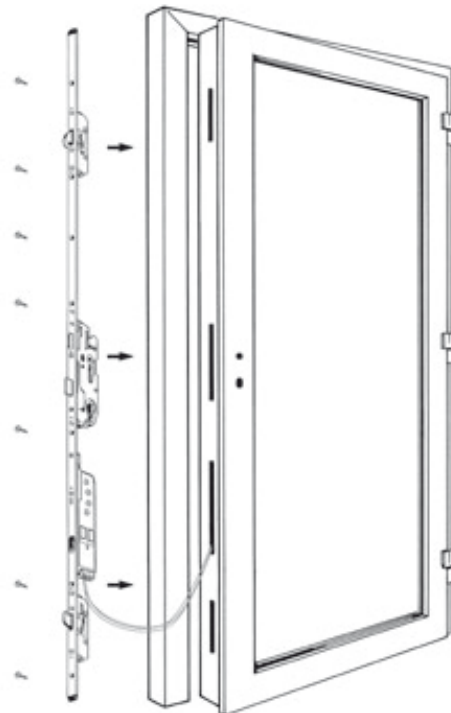
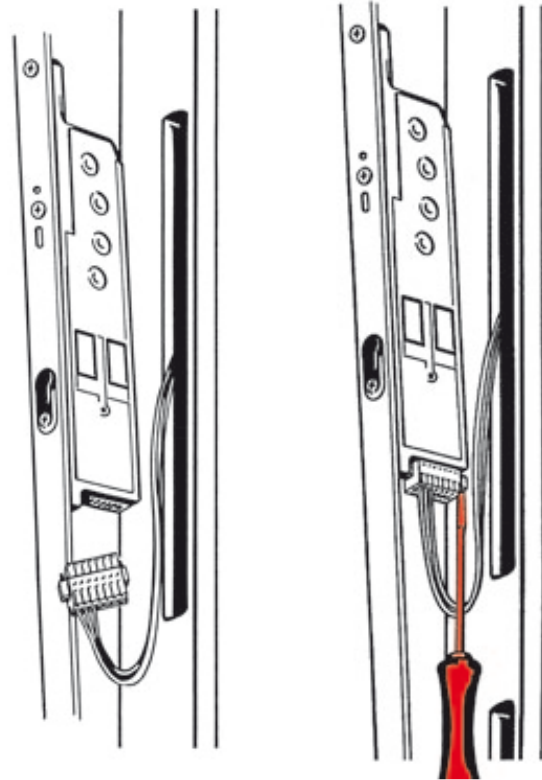

### 4.2.3 Installation of the cable guides, end caps, and cover plates in the door leaf

1. Fold the provided PVC cable guides for the profile corners in half and snap them apart for the centre profile area.
2. Clip in each of the cable guides into the top door leaf corners, and depending on the door width and height, also in the Euro groove channel.
3. Lay the cable through the cable guide and loop the surplus cable between two cable guides.
4. Crop and screw fix the cover plate according to the door width or height.

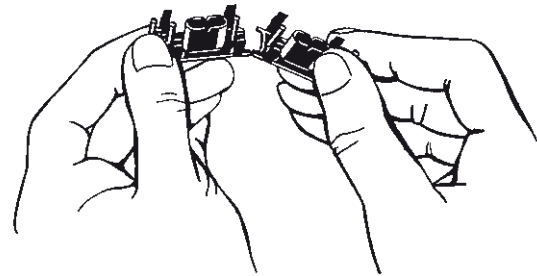

**Make sure that the screws are screw fixed through the cable guides' elongated holes. Non-compliance leads to damaged cables.**

5. Put on the end caps and screw fix through the cable guides.

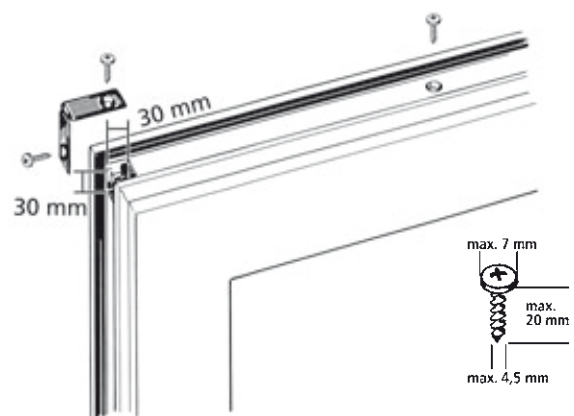
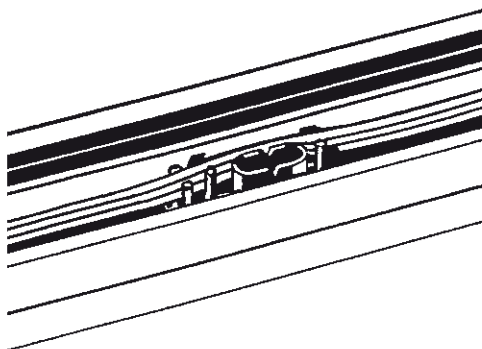
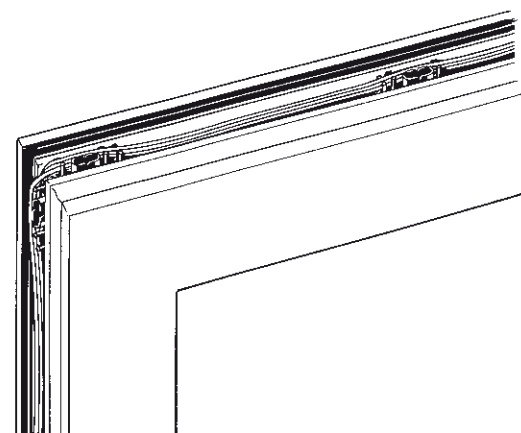
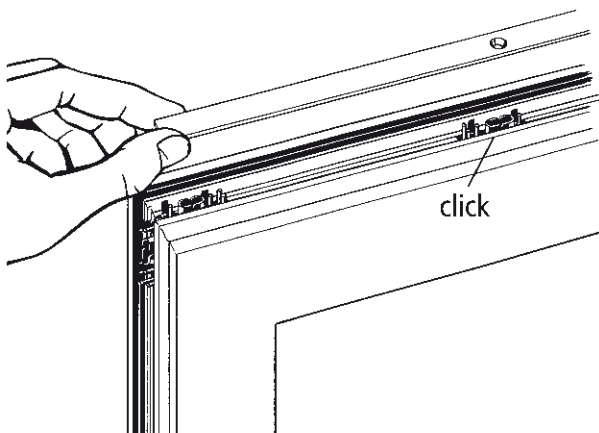

## 4.2.4 Installation of the magnetic contact in the door frame

1. Install the magnetic contact in accordance with the supplied routing drawing. The exact drawing dimension must be adhered to in order to warrant perfect contact with the electromotive drive's reed switch.



**Make sure that the reed switch and magnet are aligned horizontally at the same height.**

### For one-piece keeps:

The installation of the one-piece keep is to be carried in compliance with routing drawing provided. The magnetic contact is already integrated.

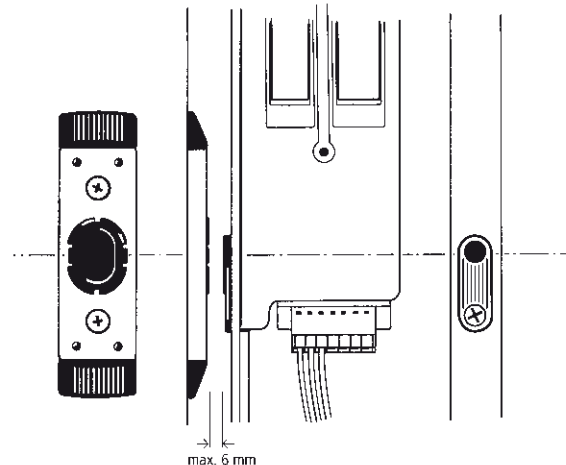

## 4.2.5 Installation of the surface-contact device in the door frame

1. Remove the silver covers.
2. Feed the surface-contact device's 3-core cable (red, black, white) through the frame profile's drill hole and back outside through the control unit casing's routed opening. Pull the cable all the way through the routed opening so that the surface-contact device is located level on the profile.
3. Screw fix the surface-contact device to the frame profile.
4. Replace the covers.



**In order to ensure proper contact and durable operation, the contact surface has been pre-treated with contact lubricant. Please do not remove this lubricant film! Please adhere to the regular maintenance instructions in compliance with chapter 7.1.**

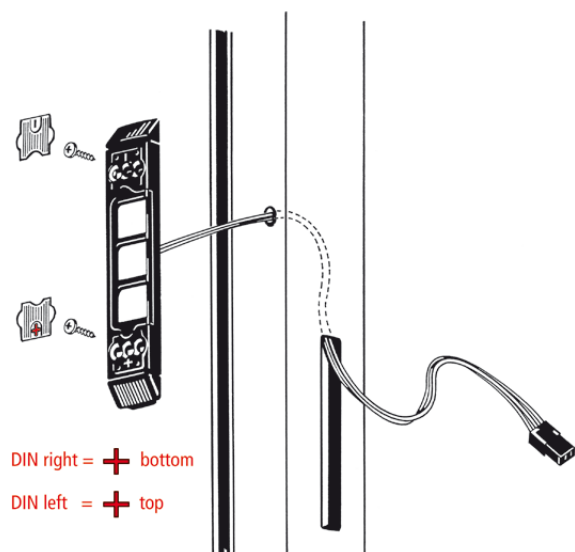



## 4.2.6 Installation of the control unit casing in the door frame

1. Remove the silver cover before installing the control unit casing. To do so, carefully insert a small screwdriver into the cover cap's recess and pry it out.
2. Connect up the surface-contact device's 3-core cable plug (red, black, white) with the control unit casing's 3-core cable plug. The plug clicks in audibly.
3. Insert the 2-core control unit casing cable into the routed recess, guide the cable downwards, and exit through the switching power supply unit's routed recess.
4. Carefully feed the control unit casing's cable back into the frame profile so that the control unit casing fits comfortably in the routed recess.



**Please ensure that the cables are neither kinked, trapped nor damaged by sharp profile edges.**

5. Screw fix the control unit casing into the frame profile.



**Make sure that the cables are not damaged when screw fixing.**

6. Replace the control unit casing's cover cap.

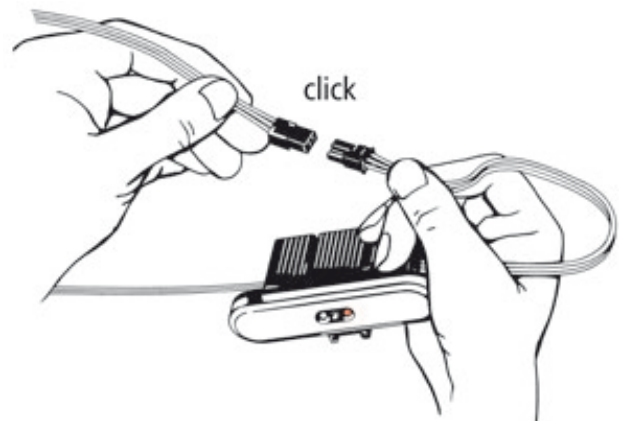
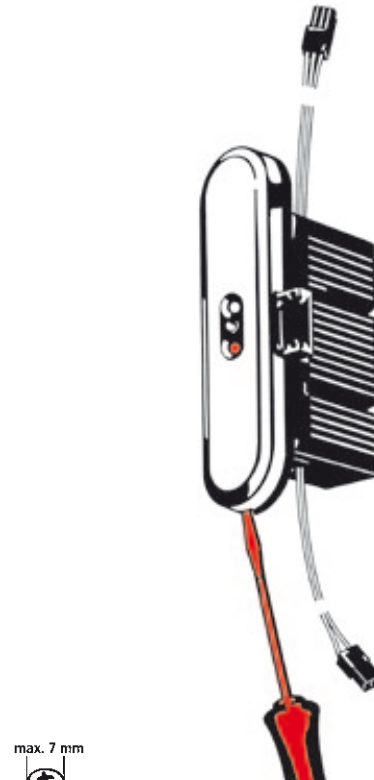

## 4.2.7 Installation of the switching power supply unit (transformer) in the door frame

The FUHR **multitronic** switching power supply unit can be used for left handed as well as right handed doors.

**On DIN right-handed doors** the switching power supply unit is installed as provided.

**On DIN left-handed doors** the top profile-related end cap is swapped with the bottom one.

1. Remove the silver covers.
2. The green/yellow earth/ground cable is to be connected electrically conducting with the door's metal frame.
3. Connect up the control unit casing's 2-core cable (red/black) with the switching power supply unit's cable counterpart. The plug clicks in audibly.

4. Feed the cable carefully back into the frame profile **ensuring that the switching power supply unit fits comfortably in the routed recess.**



Depending on the profile type, loop the cable at the bottom of the profile.

5. Guide the 230 V cable out through the deburred drill hole at the bottom of the profile (through the inserted cable protection sleeve). Leave a **spare cable loop** in the profile in order to be able to remove the switching power supply unit at a later time. Fix the rolled up cable to resist tractive forces and fasten it to the outside of the door frame using a cable tie.

6. Screw fix the switching power supply unit to the frame profile.



**Make sure that the cables are not damaged when screw fixing. Earth/ground the frame before commissioning.**

7. Replace the covers.

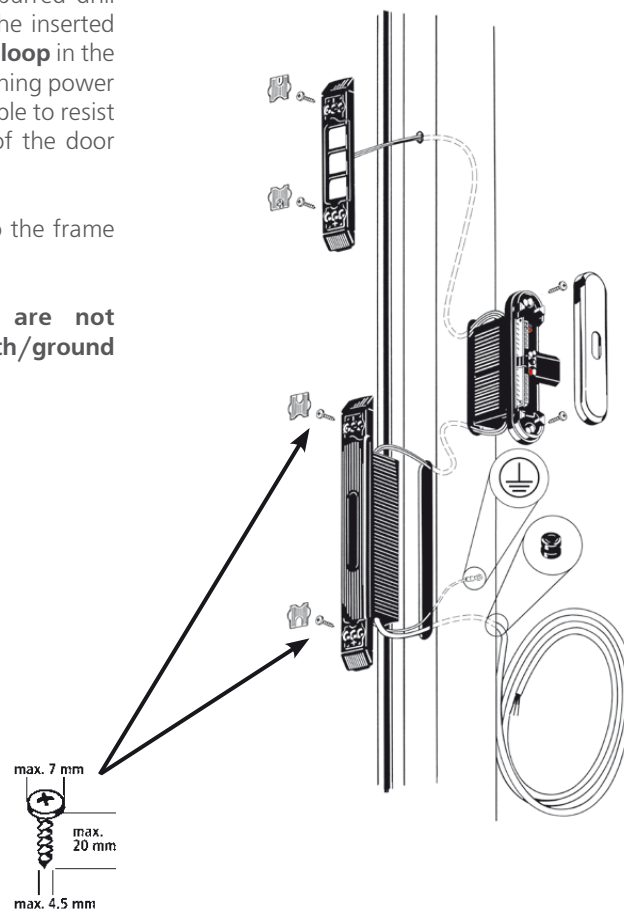
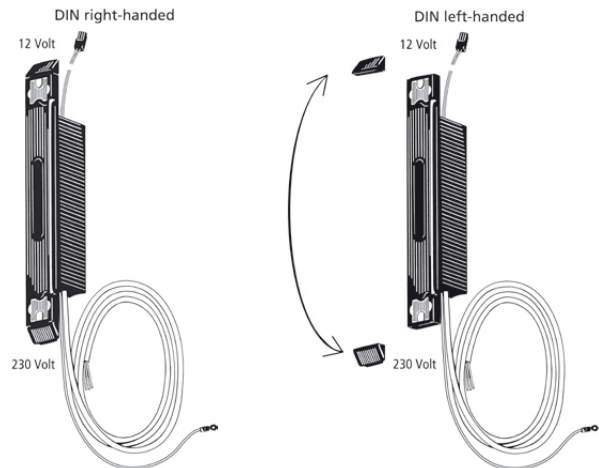

## 5 Commissioning

### 5.1 Fabricator's function check



1. After all of the FUHR multitronic components have been installed, check that the door leaves and frames are aligned parallel.

2. Install a profile cylinder with **free-running mechanism and forced decoupling** in the centre lock in accordance with the certificates of EN 179/EN 1125 resp. with the marking 'FZG'. A current list of the non-restricted cylinders which are approved with our multipoint locks can be found on our website at [www.fuhr.de](http://www.fuhr.de).
3. Subsequently connect the 230 V cable to the mains voltage by means of a two-pin earthed/grounded plug for testing purposes (only by qualified personnel).
4. The green LED will light up as soon as operating voltage is present. 3 seconds after the door is closed (the reed switch is triggered by the magnetic contact); the lock device will lock automatically.
5. In order to test all functions, the door should be opened and locked several times via the drive unit, the profile cylinder, and via the lever-handle. In the event of any problems arising, please refer to chapter 8.
6. If the FUHR **multitronic** lock is fully operational, the two-pin earthed/grounded plug can be removed and the door can be despatched.

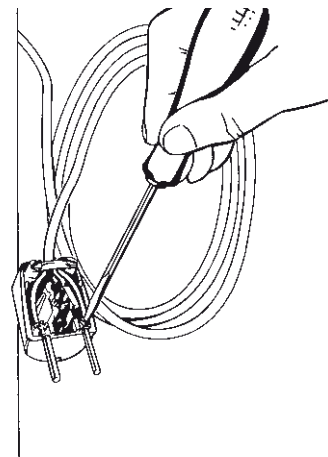
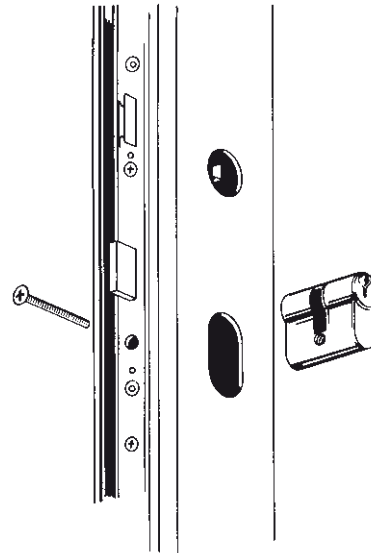

### 5.2 Commissioning on site



1. Install the door in the wall opening in the usual manner, guiding the 230 V cable to the internal side of the wall. Make sure that fixing materials (e.g. wall anchors) are not located where the electronic components are.
2. An electrician must connect up the 230 V cable to the power supply. The door frame's earthing/grounding is to be professionally checked. Conduit must be used for 230 V concealed cabling.
3. In order to be able to warrant the power supply of all electronic components, also in the case of a network operator's power failure, escape doors in accordance with DIN EN 179 and DIN EN 1125 should be equipped with an emergency power supply!

## 5.3 The radio keys (radio-controlled remote control)

The FUHR **multitronic** is supplied with 3 radio keys (radio-controlled remote controls). All radio keys are copy protected by means of a 'rolling code system'.

The radio key with the red buttons is defined as the master key and is needed to tune in the other radio keys. Up to 25 radio keys can be tuned in.

The radio keys are equipped with a three channel radio-controlled remote control. The individual buttons (channels) are allocated as follows:

Centre button – Main door – **Tuned in on site**

Left button – Free for e.g. garage door

Right button – Free for e.g. garden gate

The radio key is equipped with a battery-operated indicator light. The radio keys are particularly energy saving. One battery suffices for approx. 50,000 operations.



### Battery change:

1. Open the radio key casing with a coin.
2. Slide the battery out.
3. Insert the new battery (type: CR 2032). Note that the Plus symbol is pointing upwards.
4. Press the radio key casing together again.



#### Important!

**In order to ensure that the door can be opened in the event of an emergency (e.g. power failure), the profile cylinder key should always be carried in addition to the radio key.**

## 5.4 Master radio key

The radio key with the red buttons serves as the master key. Only this key has the ability to tune in or delete other radio keys. The master radio key's middle button has already been tuned in at the factory to the control unit within the same set.



**The master key cannot be deleted or switched at a later stage.**

**The master key should therefore be kept safely, as additional keys cannot be tuned in or deleted should it be lost.**



## 5.5 Tuning in and deleting the radio keys

### 5.5.1 Tuning in individual radio keys (max. 25)

1. During the initial commissioning, all radio keys should, for security reasons be deleted as described in chapter 5.5.3. Subsequently proceed from step 2.

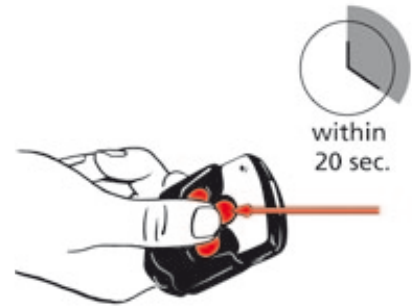

2. Close the door and press the programming button **briefly (less than 2 sec.)** between the control unit casing's red and green LED with a thin object (e.g. ballpoint pen or pencil).

3. The green LED flashes slowly.

4. Now press the master key's middle transmitter button **within 20 sec.**

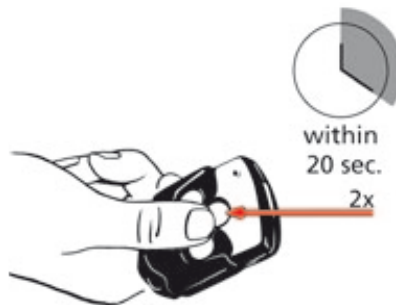

5. If the control unit accepts the master key, the green LED lights up for 2 seconds and then continues to flash slowly.

6. Press the middle button **twice** consecutively of the new radio key to be tuned in **within 20 seconds**. The tuning in procedure is aborted if the 20 second time limit is exceeded.

7. If the new radio key has been accepted by the control unit, the green LED lights up for 1 second and then goes out.

8. Repeat from step 2, should you wish to tune in another radio key.

## 5.5.2 Deleting individual radio keys (except the master key)



1. Close the door and press the programming button **for longer than 3 sec.** between the control unit casing's red and green LED with a thin object (e.g. ballpoint pen or pencil).
2. Release the programming button as soon as the green LED flashes quickly.
3. Now press the master key's middle transmitter button **within 20 sec.**

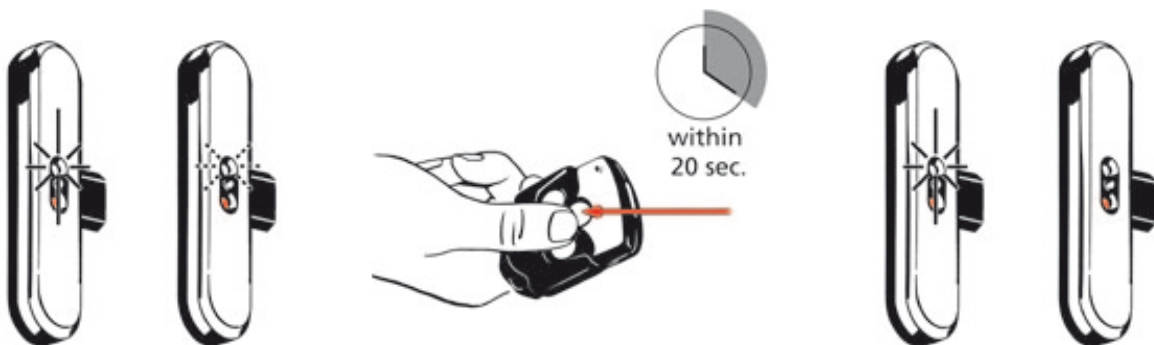

4. If the control unit accepts the master key, the green LED lights up for 2 seconds and then continues to flash slowly.
  5. Press the middle button of the radio key to be deleted **within 20 seconds**. The delete process is aborted if the 20 second time limit is exceeded.
  6. If the transmission code has been successfully deleted, the green LED lights up for 1 second and then goes out.
7. Repeat from step 1, should you wish to delete another radio key.

### 5.5.3 Deleting all radio keys (except the master key)



1. Close the door and press the programming button **for longer than 3 sec.** between the control unit casing's red and green LED with a thin object (e.g. ballpoint pen or pencil).
2. Release the programming button as soon as the green LED flashes quickly.
3. Now press the master key's middle transmitter button **within 20 sec.**

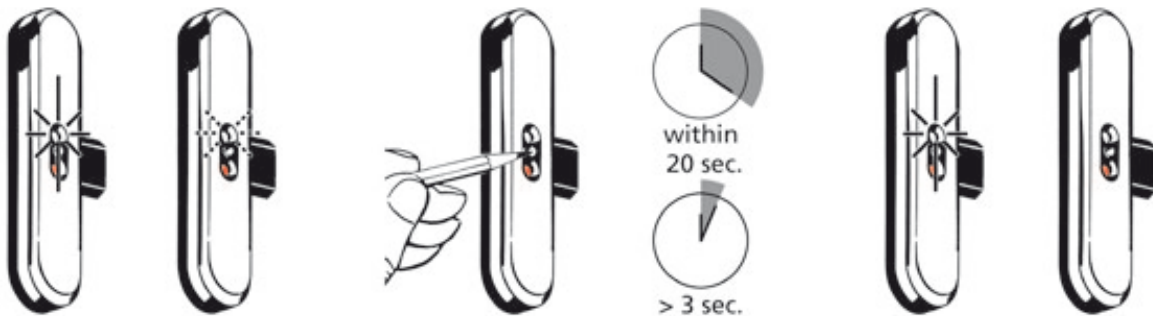

4. If the control unit accepts the master key, the green LED lights up for 2 seconds and then continues to flash quickly.
5. Now press the programming button on the control unit again **within 20 seconds for longer than 3 seconds.** The delete process is aborted if the 20 second time limit is exceeded.
6. If all of the transmission codes (except the master transmission code) have been successfully deleted, the green LED lights up for 1 second and then goes out.



**Note:** If the master key is not recognised during the tuning-in and delete processes, the respective function is aborted.

## 6 External connection options

The FUHR **multitronic** control unit is equipped with a multitude of input and output sockets to connect additional components (such as e.g. transponder, eye scan, finger print, code locks, electrical swing door opener, alarm systems, facility management systems etc.). The input and output sockets are located:

- On the frame: under the surface-mounted **control unit casing's cover** plate (refer to 6.1)
- On the leaf: **multi-functional jack** of the FUHR **multitronic** drive unit (refer to 6.2).

### 6.1 Control unit casing circuit-board

Outlined below are some examples of the potential allocation of the control unit's connection terminals.



**Note:** Equip the control unit casing mounted on the door frame with a surface-mounted cable duct if concealed cable laying of individual external connection cables is required. Connection cables pertaining to surface-mounted access control devices may be fed through this surface-mounted cable duct to the FUHR **multitronic** control unit casing.

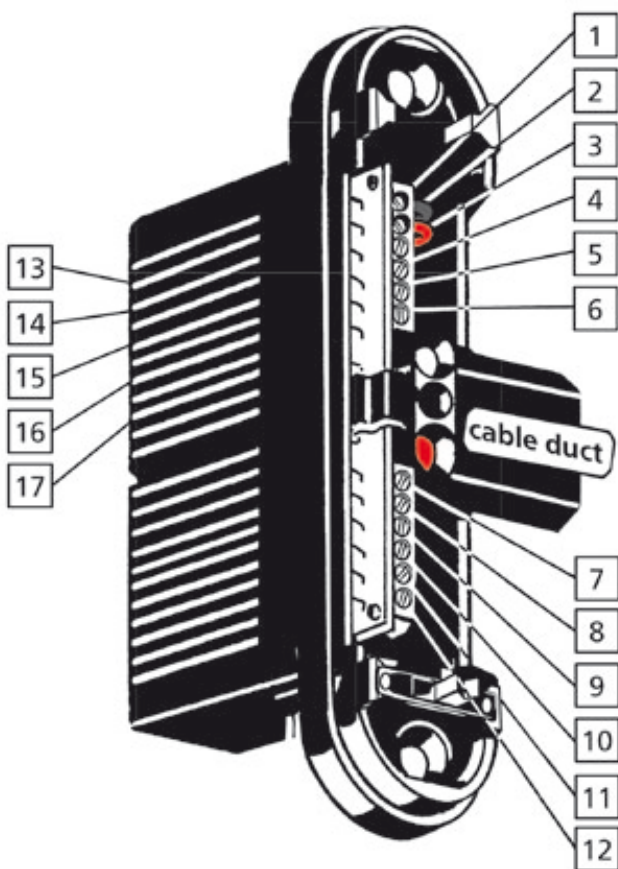

Control box with integrated mains adapter

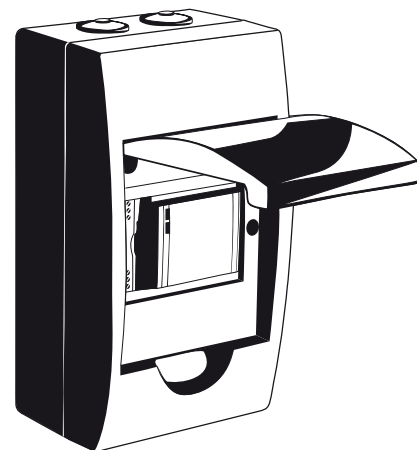

Rail-mounted control

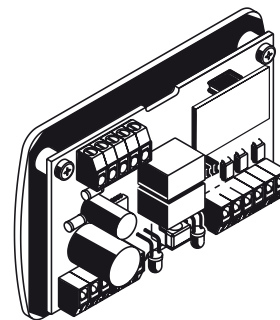



<u>Terminal</u>	<u>Assignment</u>
1 + 2:	Already occupied by the 12 V DC switching power supply unit's power supply.
3 + 4:	<p><b>Output</b> – e.g. for <b>electrical swing door openers</b>.</p> <ul style="list-style-type: none"> <li>➤ Immediately after the FUHR <b>multitronic</b> lock has been opened via radio control, transponder etc., a relay triggers the make contact for 2 seconds. This impulse is processed by the swing door opener's control unit and triggers the swinging movement of the door leaf.</li> <li>➤ The "DRT" jumper can be removed if required (refer to the wiring diagram on page 36), enabling the swing door opener's output to be triggered just as long as a continuous signal is applied to the latch retaining function (terminal 9 &amp; 10).</li> </ul>
5 + 6:	<p><b>Output</b> – e.g. for <b>alarm systems</b>.</p> <ul style="list-style-type: none"> <li>➤ Opening the door leaf and unlocking the lock triggers the related opener contact within 3 seconds. This remains triggered until the door leaf is closed over and the lock has been locked. An alarm system control unit processes the signal status and reports back 'OPEN' or 'CLOSED'.</li> </ul>
7 + 8:	<p><b>Input</b> for 6-12 V AC (alternating current) or 6-24 V DC (direct current) – optionally, this input can be used with two modes of operation:</p> <ul style="list-style-type: none"> <li>➤ <b>Function 1:</b> <b>Standard opening with subsequent complete locking after 3 seconds</b> If a <b>1 sec. impulse</b> is applied to this input (e.g. activated via a building management system) the FUHR <b>multitronic</b> lock will open.</li> <li>➤ <b>Function 2:</b> <b>Opening with day latch function</b> If a <b>continuous signal</b> is applied to this input (e.g. activated via a time switch) the FUHR <b>multitronic</b> lock will open. Upon opening the door leaf or after 5 seconds, only the lock's latch protrudes. All bolts remain withdrawn as long as the continuous signal is applied.</li> </ul>
9 + 10:	<p><b>Input</b> for potential-free signals – optionally, this input can be used with two modes of operation:</p> <ul style="list-style-type: none"> <li>➤ <b>Function 1:</b> <b>Standard opening with subsequent complete locking after 3 seconds</b> If a <b>potential-free impulse ≤ 1 second</b> is applied to this input (e.g. controlled via an access control system) the FUHR <b>multitronic</b> lock will open</li> <li>➤ <b>Function 2:</b> <b>Opening with day latch retaining function</b> If a <b>potential-free continuous signal</b> is applied to this input (e.g. controlled via a time switch) the FUHR <b>multitronic</b> lock will open. The latch and all bolts remain withdrawn as long as the continuous signal is applied.</li> </ul>
11 + 12:	<p><b>Input</b> for potential-free signals – optionally, this input can be used with two modes of operation:</p> <ul style="list-style-type: none"> <li>➤ <b>Function 1:</b> <b>Standard opening with subsequent complete locking after 3 seconds</b> If a <b>potential-free impulse ≤ 1 second</b> is applied to this input (e.g. controlled via an access control system) the FUHR <b>multitronic</b> lock will open.</li> <li>➤ <b>Function 2:</b> <b>Opening with day latch function</b> If a <b>potential-free continuous signal</b> is applied to this input (e.g. controlled via a time switch) the FUHR <b>multitronic</b> lock will open. Upon opening the door leaf or after 5 seconds, only the lock's latch protrudes. All bolts remain withdrawn as long as the continuous signal is applied.</li> <li>➤ The "TGF" jumper can be removed if required (refer to the wiring diagram on page 36), enabling the lock's latch to <b>no longer</b> retract motor-driven upon the first day-latch activation.</li> </ul>
13 - 15:	Already occupied by the electricity and data transmission.
16 + 17:	<p><b>Input</b> for potential-free signals.</p> <ul style="list-style-type: none"> <li>➤ All motorised opening functions (radio receiver and control terminals 7-12) are deactivated as long as this input remain triggered. The opening impulses via the motor's circuit board (terminal 4/7) are also deactivated.</li> </ul>

## 6.1.1 Application examples for circuit board assignment

### Application example in residential buildings:

For example the door shall be opened via radio key from the outside. The opening is triggered from the inside by means of an existing two-way intercom system with a 12 V AC control cable. This was, as the case may be, used previously for an electrical door opener.

#### Terminal assignment:

Connect the two-way intercom system's cables to terminal 7 + 8.

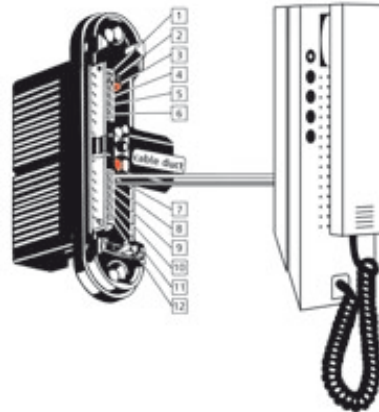

### Application examples in residential/public buildings:

The opening shall be triggered from the outside by means of an access control system (e.g. numeric code lock or finger print).

#### Terminal assignment:

Connect the access control system with potential-free impulse ( $\leq 1$  sec.) to terminals 11 + 12.

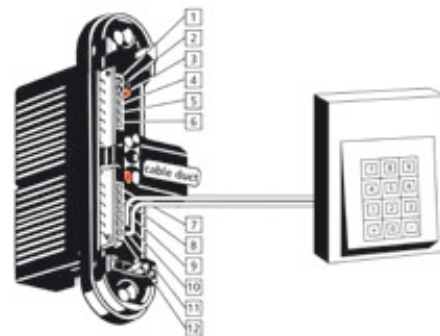

### Application example in construction projects:

The door shall be locked during the day for example by means of the latch only. At night the lock shall be locked both completely and fully automatically. Opening from the outside is triggered by means of an access control system (e.g. numeric code lock or finger print). In addition, an electrical swing door opener shall open the door leaf.

#### Terminal assignment:

Connect the time switch with potential-free continuous signal to terminals 11 + 12 for function 2.

Connect the access control system with potential-free impulse ( $\leq 1$  sec.) to terminals 9 + 10 for function 1.

Connect the swing door opener to terminals 3 + 4.

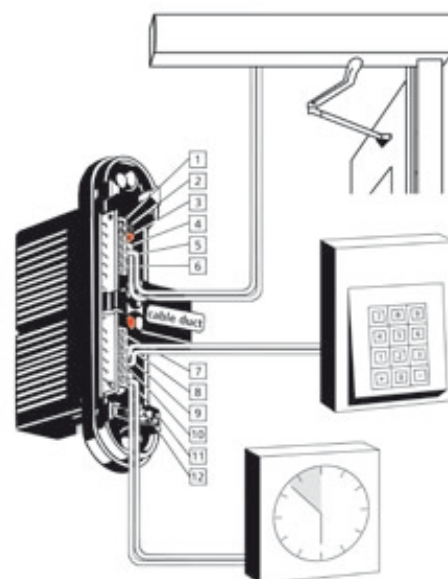

## 6.2 The drive unit's multi-functional jack

The below-mentioned applications are merely intended as application examples of common connections. Furthermore there is a multitude of other possible applications.



**It is important that the respective switching signal (e.g. the 12 V DC impulse or the potential-free contact etc.) is connected to the appropriate terminal.**

<u>Terminal</u>	<u>Assignment</u>
1 + 2 + 3	Already occupied by the 12 V DC drive unit's power and data supply cable.
4 + 5	<b>Input</b> (impulse < 1 sec.) – e.g. for <b>external access control systems (transponders, code locks, finger print, eye scan... etc.)</b> , that are mounted directly on the door leaf. ➤ By means of either the access control system's control unit or by pressing a switch, a brief potential-free contact triggers opening the FUHR <b>multitronic</b> lock.
5 + 6	<b>Output</b> – ideally used for the power supply of <b>illuminated fixed pad handles or illuminated glazed panels</b> . ➤ Terminal 5 = GND (earth/ground) and ➤ terminal 6 = 12 V DC (max. 350 mA).
5 + 7	<b>Input</b> (impulse 1 sec.) – e.g. for <b>code locks or transponder systems</b> , that are mounted directly on the door leaf. ➤ Terminal 5 = GND (earth/ground) and ➤ terminal 7 = 12 V DC ➤ Input signal to open the lock = 12 V DC.

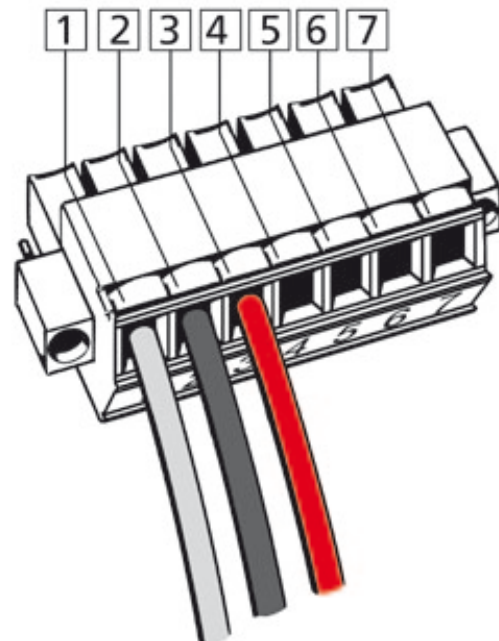

**We recommend the use of shielded cables in order to avoid interference from external sources and ensure proper functioning.**

## 7 Maintenance and care



The points raised below are intended as an addition to the FUHR product information M3/3. The importance of their compliance must be pointed out to builders and users alike. In the event of non-compliance with these necessary instructions, faultless operation of the locks cannot be guaranteed. The FUHR multitronic lock may only be used in conjunction with the components provided. Failure to do so invalidates warranty issues.

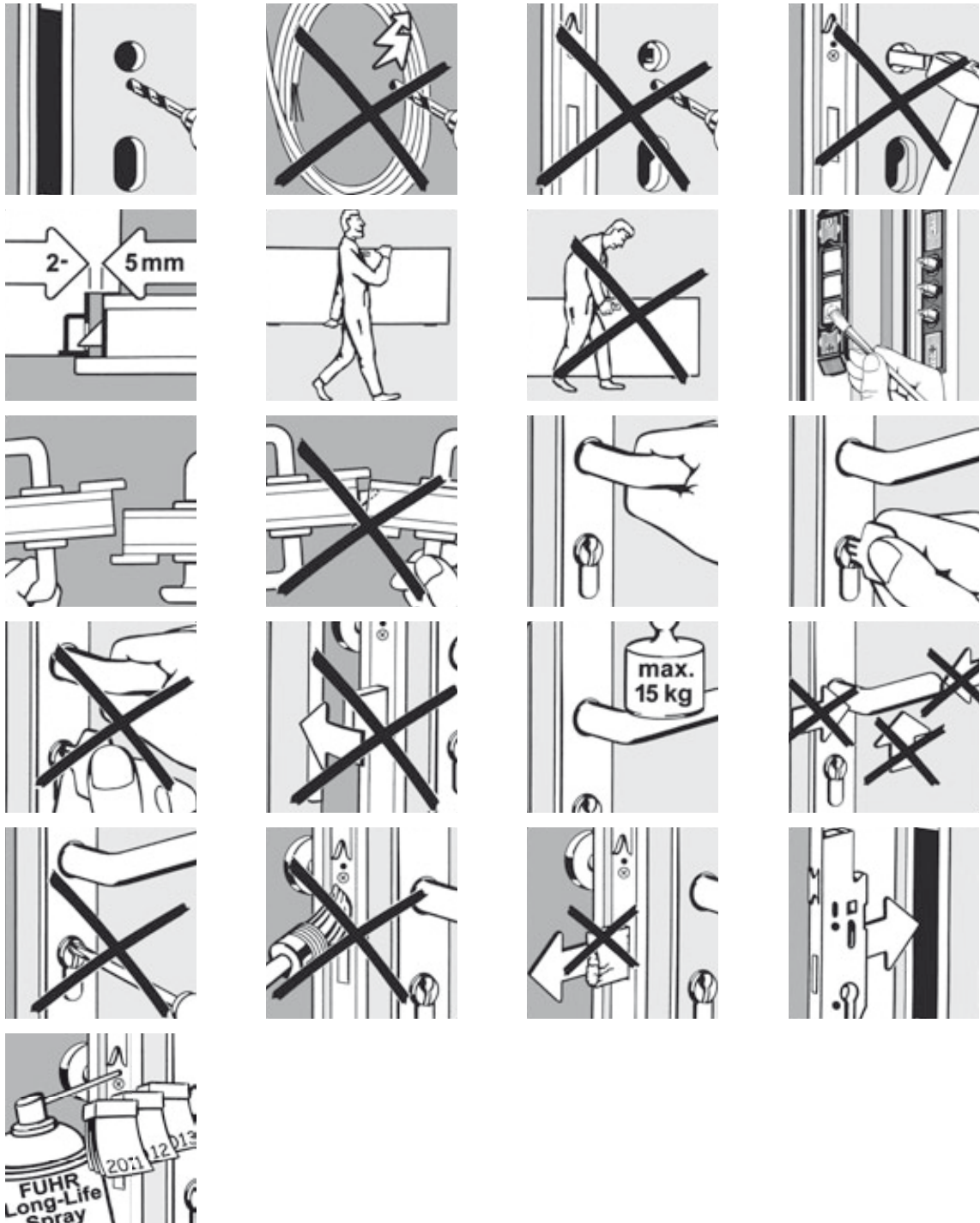

All safety-relevant hardware must be checked at least annually for wear and tear and if mechanically secured. Depending on the requirements, fixing screws must be tightened or the damaged or worn parts exchanged for original parts by a specialised company.

Additionally all movable parts and locking points must be lubricated and their function must be checked. Only cleaning and maintenance agents, which do not damage the corrosion protection of the hardware components, are to be used. Hardware adjustments as well as replacing hardware components must be carried out by a specialist company.

**We recommend you consider a service and maintenance contract with a specialist company.**

## 7.1 Contact device



In order to ensure perfect contact between the contact surfaces and the tappet contacts, we recommend that the surfaces are treated with the provided contact lubricant twice a year.

(The contact lubricant can be reordered under the item no. NZ80077.)

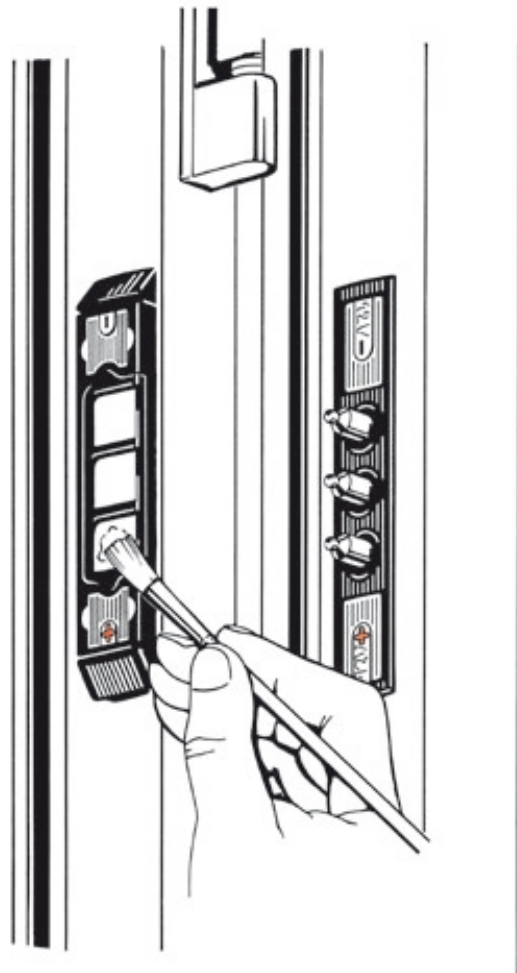

## 8 Troubleshooting

In the event that your FUHR **multitronic** lock should fail to function properly, please refer to the table below to find and rectify the fault.



**IMPORTANT!** The entire FUHR **multitronic** lock has been subject to extensive inspections by the manufacturer. If faults are found once installed, the installation should be checked to begin with. The FUHR **multitronic** lock must never be opened forcefully using the lever-handle! All components have been designed for a smooth running operation. The FUHR **multitronic** lock has not been designed to straighten out warped or distorted doors! Careful and proper installation and maintenance of the door is a prerequisite for durable, trouble free operation.

Type of fault	Signal	Possible cause of fault	Fault repair
The lock does not lock completely.	Green and red LEDs flash alternately.	Deadbolt doesn't run smoothly.	Open the lock using the radio key or the key. ( <u>Not with force via the lever-handle!</u> )
		The door is warped.	Check the door installation and possibly adjust.
		The keeps have been adjusted too tightly.	Readjust/loosen keeps.
		The locking bolts are obstructed.	Check as to whether all keeps are freely accessible.
The lock does not lock or unlock.	Green and red LEDs light up.	A profile cylinder without free-running mechanism has been installed.	Install a non-restricted profile cylinder (refer to 5.1).
		Data connection between the electronic drive unit and the control unit is interrupted.	Check if the spring-loaded tappet contacts are correctly poled (note +/-; refer to 4.2.1 and 4.2.5).
		One or more cables are damaged.	Are the spring-loaded tappet contact pins meeting the flat surface contact when the door is closed over? Check all cables and plug-and-socket connections.
		Tappet contacts and contact surfaces have no contact.	Lubricate the contact surfaces (refer to 7.1).
The lock does not lock.	Green LED lights up.	Reed switch is not triggering. Magnet is out of range.	Readjust the magnet and/or door. Check the clearance.
		<u>No</u> LED lights up	Power and data connection between the electronic drive unit and the control unit has short-circuited. Check if the spring-loaded tappet contacts are correctly poled (note +/-; refer to 4.2.1 and 4.2.5). Connect the cable properly to the green multi-functional jack (refer to 6.2).

Type of fault	Signal	Possible cause of fault	Fault repair
The door cannot be opened by the radio key or by an external opening impulse.	Red LED lights up.	The radio key is not tuned in.	Tune in the radio key.
		The distance to the receiver is too large.	Hold the radio key closer to the door.
		The batteries in the radio key are too weak.	Hold the radio key closer to the door and replace the battery.
		The control software is blocked.	Reset the control (switch the power supply off and on).
Door was opened.	Green and red LEDs light up.	This is <u>not</u> a fault. A signal is being transmitted to indicate that the door has been open for more than 20 seconds.	Close the door. The lock will lock automatically.
Latch remains retracted.		The connecting rods are blocked by faceplate screws.	Insert the screws perpendicular to the faceplate.
		External control signal is applied to terminals 6-12 for too long.	Reduce the pulse duration to $\leq 1$ second.

## 8.1 Adjustment of strike plates/one-piece strike plates and latch changing

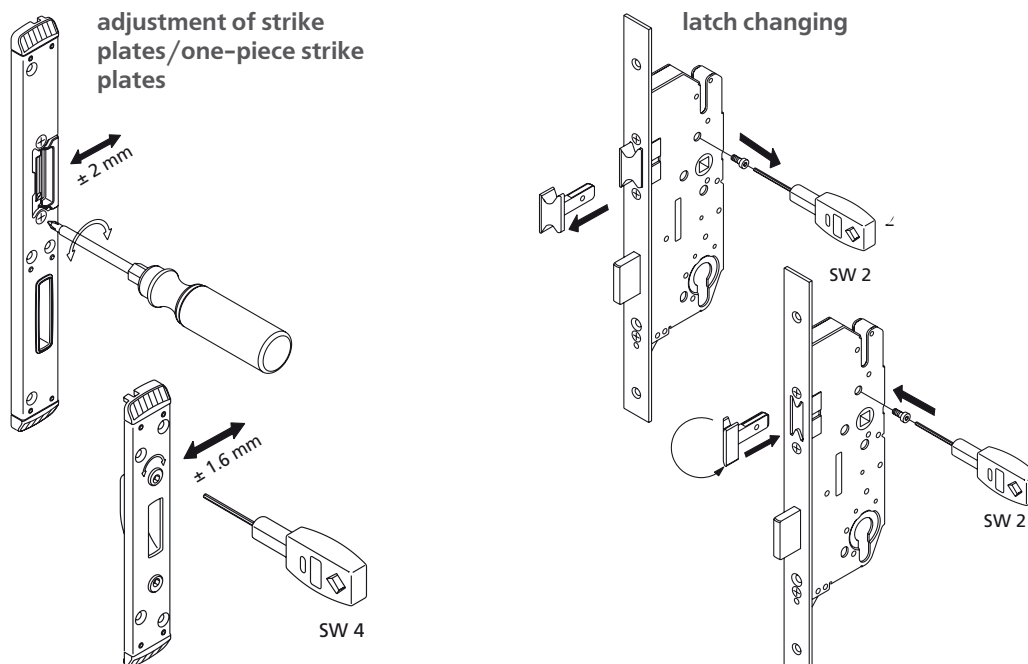

## 9 Technical data

### 9.1 FUHR multitronic set

#### Power consumption

for standby operation including the 12 V DC mains adapter:	Approx. 65 mA
during the closing movement:	Approx. 450 mA
during the opening movement:	Approx. 400 mA
while the latch retracts for approx. 5 seconds:	Approx. 250 mA
Start-up current of motor:	Approx. 1 A
Brief current peak while blocked:	Approx. 1.7 A
Temperature range:	- 10 °C to + 50 °C
Door leaf weight:	Max. 200 kg

### 9.2 FUHR multitronic radio key (remote control)

The radio keys conform to the R&TTE guideline 1999/5/EG

Coding:	Not necessary as the transmission code will be tuned in
Channel:	868.3 MHz
Channels:	3
Modulation:	FSK (frequency shift keying)
Range:	Up to approx. 50 m. depending on the installation circumstances
Power supply:	1 x 3 V battery, CR 2032
Operating control:	Light emitting diode (LED)
Temperature range:	- 10 °C to +50 °C
Dimension:	53 x 36 x 15 mm
Weight:	Approx. 20 g. (including battery)
Delivery scope:	1 master radio key with red buttons and 2 radio keys with turquoise buttons (all supplied with battery)

### 9.3 FUHR multitronic control unit with radio receiver

Coding:	Not necessary as the transmission code will be tuned in
Channel:	868.3 MHz
Modulation:	FSK (frequency shift keying)
Aerial:	Cable aerial approx. 110 mm
Power supply:	12 V DC
Operating control:	2 light emitting diodes (LEDs)
Temperature range:	- 10 °C to +50 °C
Dimension:	120 x 45 x 25 mm
Weight:	Approx. 75 g. (incl. cable and casing)
IP rating:	IP 20
Alarm output:	Max. contact load capacity 125 V AC/1 A/62 VA

### 9.4 FUHR multitronic drive unit

Dimension:	50 x 206 x 15.5 mm
Weight:	Approx. 500 g. (only electrical locking unit)
Power supply:	12 V DC via power and data transfer cable
Signalling:	1 piezo buzzer
Temperature range:	- 10 °C to +50 °C
Relay contact load capacity:	60 V DC/1 A/30 W



## 9.5 FUHR multitronic switching power supply unit

Model: Primary switching controller (single phase, primary clocked built-in power supply)  
Impulse load capacity, short circuit protected, open-circuit proof, high efficiency, thermal overload protection

Tested in accordance with: EN 60950  
EMV: EN 50081-2 (emitted interference)  
EN 61000-6-2 (interference resistance)  
Test voltage: 4.2 KV  
Type of construction: Cable cast in the contact  
IP rating: IP 20 with plug (IP 53 without plug)  
Protection grade: Prepared for protection grade I devices and systems  
Ambient temperature: -20 °C to +60 °C (0 °C to 40 °C without derating)  
Relative humidity: 5 to 80 %  
Cooling method: Self-cooling by means of natural convection  
Storage temperature: -25 °C to +85 °C

Input voltage range: 230 V AC input (180 to 264 V input voltage range)  
Channel: 50 to 60 Hz  
Input current: Type 0.7 A at 230 V AC  
Switch-on current: < 15 Ap  
Mains power failure bridging: > 20 ms at 230 V AC nominal voltage  
Overvoltage protection: Yes  
Connections: 3 m cable with 3 x 0.75 mm<sup>2</sup>

Output voltage: 12 V DC stabilised 2% (SELV)  
Output current: 2.0 A 100 % ED/Duty Cycle  
3.5 A at 5 % ED/Duty Cycle  
Ripple: < 100 m Vpp (at 20 MHz bandwidth)  
Control deviation: Max. 2 %  
Current limiting: Refer to the characteristic line in the diagram

Efficiency: Type 79 %  
Connections: 300 mm x 0.75 mm<sup>2</sup>

Dimension: 230 x 25 (29) x 35 mm  
Weight: Approx. 350 g. (including cable)

U/I characteristic line:

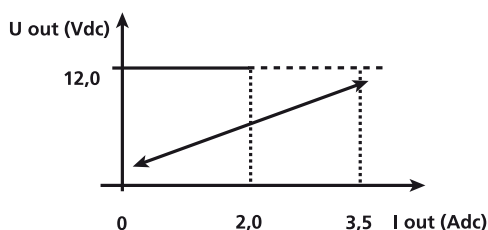

## 10 Optional accessories

### 10.1 Radio fingerprint scanner

Biometric system for convenient, keyless access control. With 2 channel technology, opening impulse via rolling code process.

Item no. NB366  
Item no. NB252N (cover)  
Please order the cover separately.

Version with flat stainless steel cover  
Item no. NB649N

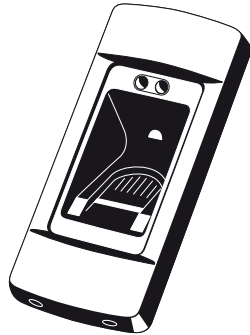

### 10.2 Radio transponder reader

For non-contact code transmission of car keys and transponders to the control unit. With 2 channel technology, opening impulse via rolling code process.

Item no. NB403  
Item no. NB540 (without programming/pairing function for car keys)  
Item no. NB252N (cover)  
Please order the cover separately.

Version with flat stainless steel cover  
Item no. NB688N  
Item no. NB693N (without programming/pairing function for car keys)

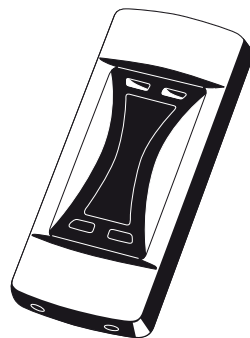

### 10.3 Radio keypad

For a code transmission by entering a numeric combination. With 2-channel technology and an additional radio gong channel. Opening impulse via rolling-code process.

Item no. NB404  
Item no. NB405N (cover)  
Please order the cover separately.

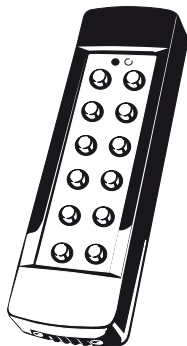

### 10.4 Comfort access system SmartTouch

Active transponder system offering keyless door opening. The set consists of receiver module, sensor and master transponder.

Item no. NB506N

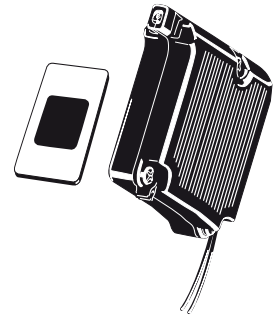

### 10.5 Radio receiver module

Pluggable onto the motor drive, compatible with all FUHR radio control modules. A separate control is not necessary. Connects directly to the motor drive socket. 2-wire technology between mains adapter and motor drive is sufficient. 25 transmitters programmable. For motor drives with plug-in device.

Item no. NBFP490

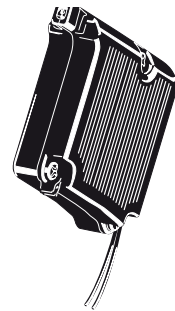

### 10.6 Built-in transmitter for intercom systems

For installation in intercom systems. Sends a signal to open the door when powered with a voltage between 5-24 V AC or 6-32 V DC. With pre-assembled connection cable.

Item no. NZ80123



### 10.7 Radio push-button switch

Enables convenient door opening from the inside at the touch of a button. Wireless – can be installed anywhere. Battery operated. Silver with glass frame.

Item no. NZ80021AS

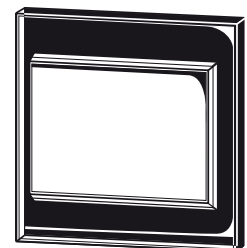

**10.8 Power socket radio receiver**

Designed for use with two-pin earthed/grounded plug-sockets. For triggering existing electrical drive units via radio key, e.g. garage doors.

Item no. NZ80088

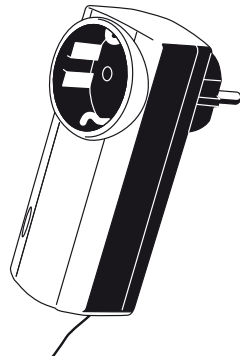

**10.9 Plug socket radio gong**

Suitable for Schuko electric plug sockets. Receives the signal emitted by radio keypad or radio wall-mounted switch. Also applicable for doors in nursery schools.

Item no. NZ80122



**10.10 Universal adapter**

Optional extra to connect to existing control units (e.g. from garage door drive units). External power supply necessary (12-24 V AC/DC).

Item no. NZ80023

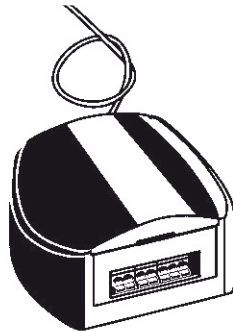

**10.11 Radio keys**

Additional radio key with turquoise buttons.

Item no. NZ80062



**10.12 User transponder**

Additional user transponder (3 user transponders are included in delivery of transponder reader).

Item no. NZ80104



**10.13 Indicator LED for the exterior side of the door**

Can be used optionally as a visual indicator of the locking status.

Item no. NZ80067



**10.14 Cover for the control unit with sliding switch and connection cable**

Enables the manual activation of the day latch function (connection to terminals 11 + 12) or daylatch retaining function (connect to terminals 9 + 10).

Silver  
Item no. NZSTZ0265  
Stainless steel  
Item no. NZSTZ0459

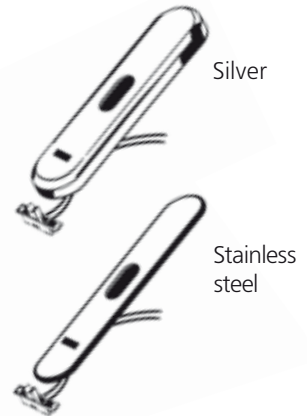

**10.15 Contact grease**

For contact areas to guarantee connection between the contact surfaces and tappet contacts.

Item no. NZ80077

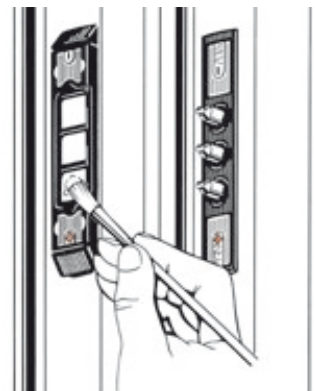

1 INTRODUCTION

2 IMPORTANT INFORMATION

3 DELIVERY SCOPE

4 INSTALLATION INSTRUCTIONS

5 COMMISSIONING

6 EXTERNAL CONNECTION OPTIONS

7 MAINTENANCE AND CARE

8 TROUBLESHOOTING

9 TECHNICAL DATA

10 OPTIONAL ACCESSORIES

# 11 Wiring diagram

**Power supply via switching power supply unit**  
min. 12 V DC / 3A (residual ripple < 250 mVpp)

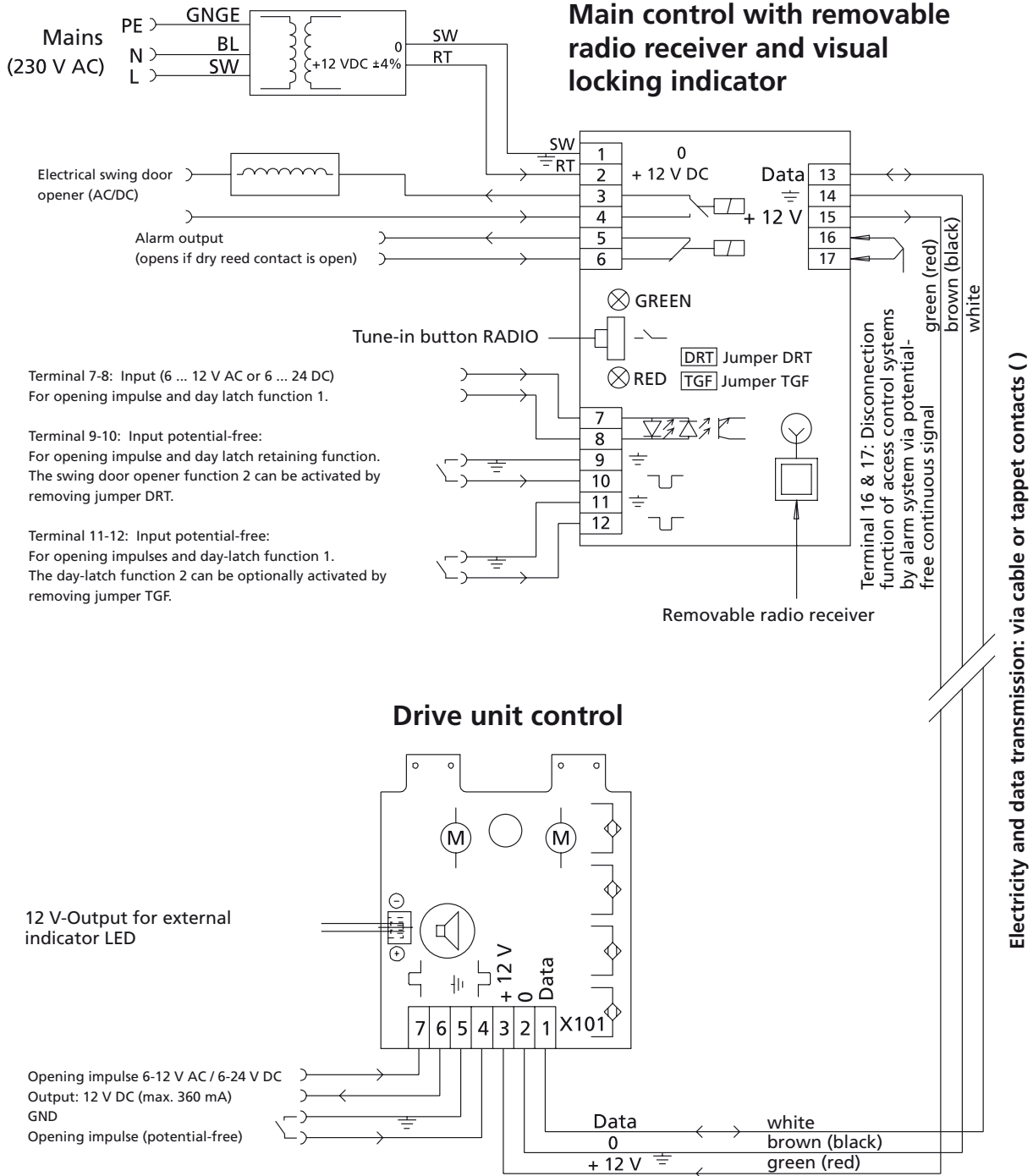

**Note:** In order to activate the alarm system function via terminal 16 and 17, both the motor's circuit board as well as the control unit's circuit board require software release 4.3 or higher.